

# AR407



## 16-Channel radio and wired data recorder

The AR407 allows the creation of a radio and wire based measurement network based on Apar production equipment (AR43x radio sensors, AR182 / AR183 temperature probe, or any RS485 or Ethernet interface). The system enables remote measurement and recording of temperature and humidity or other physical quantities (pressure, level, speed, etc.) processed into a standard electrical signal (0/4 ÷ 20 mA, 0 ÷ 10 V, 0 ÷ 60 mV).

AR407 base station allows simultaneous presentation of up to 16 measuring channels, both radio and wired (devices connected via RS485 interface with MODBUS-RTU protocol or Ethernet with MODBUS-TCP or AR18x temperature probe).

Radio transmissions are in the ISM 868 MHz band with FSK modulation up to 200 m (or 400 m) in open space. In buildings, the range depends on structural elements such as the type and thickness of walls, ceilings, doors, etc. For up to a maximum of 400 meters, any sensor that communicates directly with the AR407 base station can be programmed to retransmit measurements from other sensors located in its range. The retransmitter function requires a power supply with a standard mini USB plug. There may be up to 3 retransmitters per network. Seven radio channels allow the independent operation of neighboring AR407 sets with sensors, which together allows up to 112 measurement channels to be registered.

Measurements from related devices are transmitted radio or wire to AR407, which can record this data in internal memory or USB. Access to the AR407 base station is via Ethernet, USB or RS485. The AR407 recorder also has a built-in web server so you can view current measurements on the LAN and the Internet, additionally the ability to generate e-mail alerts.

Free software enables configuration and monitoring of devices (ARSoft-CFG) and archiving of measurement data and report generation (ARSoft-LOG).

### Sample network diagram:

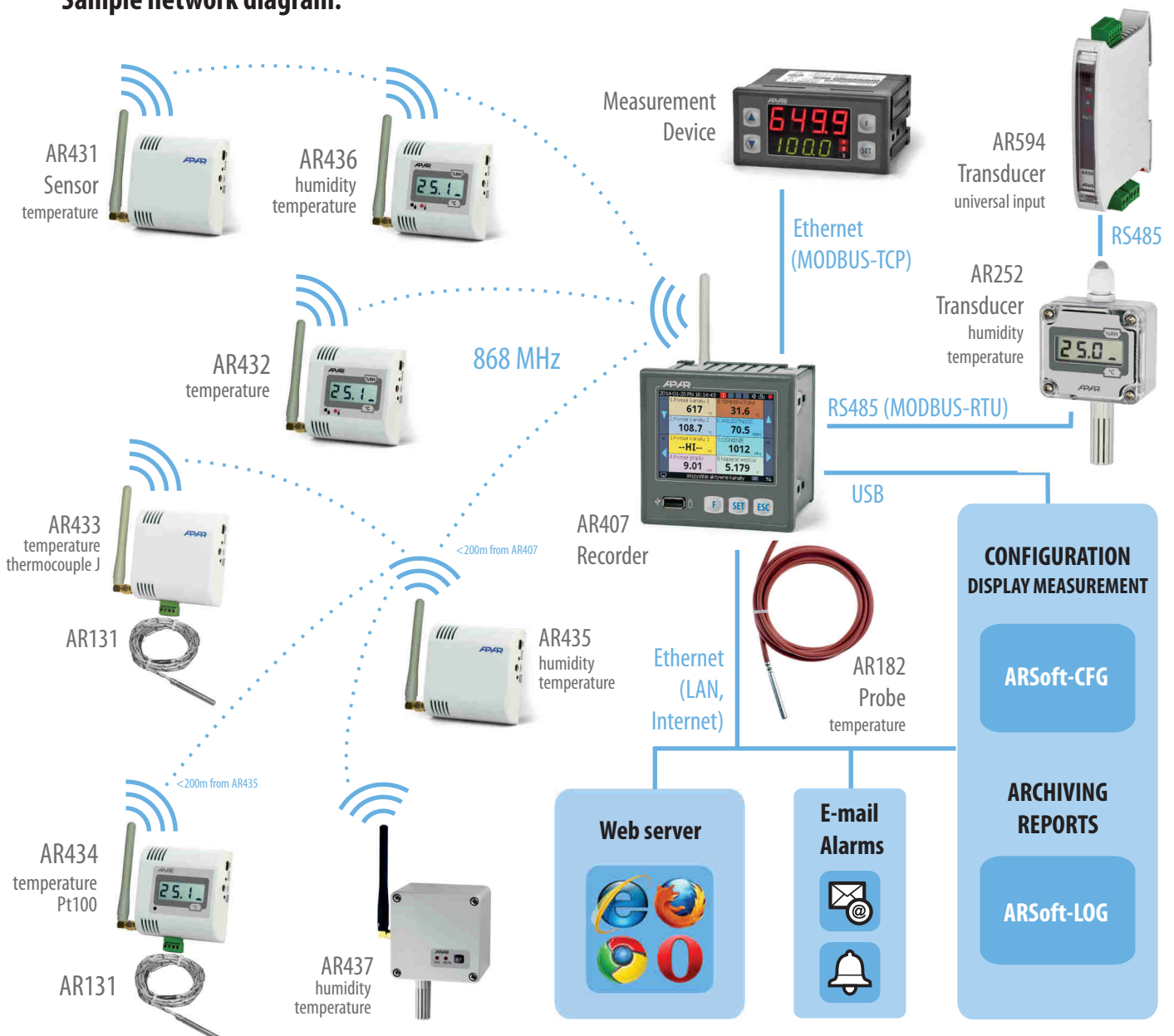

# AR407

## 16-Channel radio and wired data recorder



### Methods of data presentation

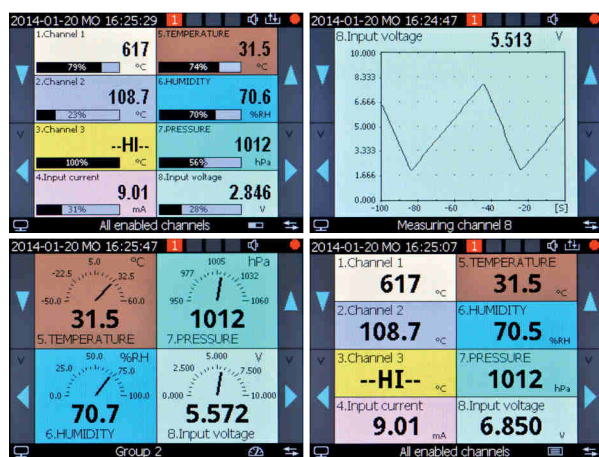

### Web server

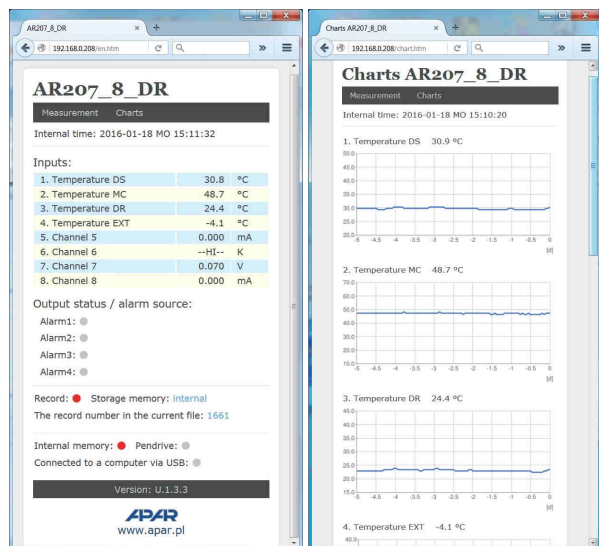

- presentation and recording of data from a maximum of 16 measurement channels assigned to such Apar devices as wireless sensors of the AR43x series, one wireless temperature probe (AR182 or AR183), and any devices with an RS485 or Ethernet interface using the MODBUS-RTU and MODBUS-TCP protocols
- available wireless sensors: AR431, AR432 - temperature (one measurement channel), AR435, AR436, AR437 - humidity and temperature (two channels), AR433, AR434 - two channels, ambient temperature and a universal input (Pt100/Ni100/J/K/S/B/R/T/0÷20mA/ 4÷20mA/0÷10V/ 0÷60mV/0÷700Ω)
- radio transmission in the ISM 868MHz band, range in an open space of up to 200 m (or 400 m) depending on the local conditions for propagation of radio waves: the type and thickness of walls, floor slabs, etc.
- the radio range can be increased to 400 m by switching on the measurement retransmission function in the sensors (retransmission requires power supply of the sensors and no more than 3 retransmitters may be present in the network)
- 7 radio channels enabling independent operation of 7 neighboring AR407 sets with sensors
- 4 bistate alarm/control output with timer, sound and visual signaling of the operation status and with email notification, programmable alarm characteristics and value of the output signal (in the range of 1÷100% of the impulse period) with the possibility to assign to any measurement channels
- a color LCD TFT graphic display 320x240 dots (QVGA), with a touch screen, brightness adjustment, and programmable background color for individual measurement channels
- rich standard equipment with serial interfaces: USB (for work with a computer and USB memories), RS485 (MODBUS-RTU Master and Slave), and Ethernet (100base-T, MODBUS-TCP, HTTP, and SMTP protocols, etc.)
- recording of data in a standard text file located in the internal memory of the recorder (4 GB) or an USB memory in a FAT system, with possibility to edit in spreadsheet software, e.g. Microsoft Excel
- possibility to transfer archive data and configuration data to a USB memory, USB port or via Ethernet
- a web server for work with any web browser (Opera, Edge, IE, Firefox, etc.); the site contains information about active measurement channels, time, status of the outputs, recording, etc., with the possibility to show diagrams using the Google Chart API service (diagrams require constant Internet access)
- the DDNS service, which enables easy access over the Internet a recorder connected to a network that has no fixed public IP address, through a friendly Internet address defined by the user; the service is available only for registered users of popular DDNS services, such as DynDNS (www.dyndns.org), No-IP (www.no-ip.com), and DNS-O-Matic (www.dnsomatic.com)
- a programmable F button for quick selection of one of the available functions: start/stop of recording, copying or moving archives to a USB memory, blocking of outputs, sound alarms or the touch screen and the keypad, status of the device and of internet services
- programmable types of sensors, ranges of indications, alphanumeric description of measurement channels and measurement groups, recording, alarm, display, communication, and access options, and other configuration parameters
- access to configuration parameters protected with a user password
- parameter configuration methods: from the film keypad and a touch screen located on the front panel of the device; through the USB, RS485, or Ethernet and free ARSOFT-CFG (Windows 7/8/10) software or a user's application, communication protocol MODBUS-RTU and MODBUS-TCP; from configuration files saved in the USB memory or on a computer disk
- available protection of measurement data from unauthorized modification (check sum)
- graphic and text methods of presentation measured values (numerical values, bar graph, counter, graph)
- grouping of measurement channels to be displayed, with automatic formatting of the screen
- internal real time clock with a battery backup power supply (up to 8 years of continuous operation)
- free software provided that enables presentation and printing in a graphic or text form of the recorded results (ARSOFT-LOG) and configuration of parameters (ARSOFT-CFG)
- recording of data until the memory is full (at least 300 days of continuous operation with recording of 16 channels every 1 s)
- a broad selection of recording start methods (continuous, limited by date and time, periodic daily, above or below the permission threshold assigned to any measurement channel)
- possibility to differentiate archives from many recorders of the similar type by assigning individual ID
- intuitive use, clearly visible status of operation of the recording, the memory, the USB port, alarms, etc.
- compliance with the RED (2014/53/UE) directive and high immunity to interference
- possible update of the recorder software by the user to the latest version from a USB memory

### Contents of the set:

- a recorder with an antenna for the 868MHz band
- a USB cable for connecting the device to a computer, 2 m long
- non-obligatory CD with the drivers and the software (Windows 7/8/10, available also at www.apar.pl)
- a user instruction and a warranty card

### Available sensors and accessories:

- wireless sensors of the AR43x series (AR431/432/433/434/435/436/437)
- a wired ambient temperature sensor AR182 (on a wire) or AR183 (boxed)
- an antenna cable SMA with a socket and a plug, impedance 50 Ω, 2 m long
- a USB memory (2 or 4 GB)

## TECHNICAL DATA

<b>Number of measurement channels</b>	16 (for work with radio sensors of the AR43x series, one wired probe AR182/AR183, and any Apar devices through RS485 or Ethernet interface with MODBUS-RTU/TCP protocols)	
<b>Measurement update interval</b>	AR43x series: programmable, from 1 min. to 4 hours (5 sec. with ext. supply) 1 sec. for the RS485 and Ethernet line (2), 5 sec. for a wired AR182/AR183 probe	
<b>Radio link</b>	band	ISM, 868 MHz, FSK modulation, modulation band width $\pm 45$ kHz
	number of channels	7 (programmable in the range of 868.0 to 870.0 MHz)
	rate	4,8 kbit/s
	radio output power	<5 dBm
	sensitivity	-106 dBm
	range (in open space)	<200 m (maximum 400 m with sensors in retransmission mode), in buildings it depends on the local conditions
	antenna	SMA-JW connection (band 850 ÷ 880 MHz) height 97 mm, vertical polarity, impedance 50 $\Omega$ , gain 2.15 dBi, VSWR $\leq 1.5$
<b>Wired temperature measurement probe AR182/AR183 (as one of the measurement channel, optional):</b>		
	- quantity	1, wire length 1,5 m
	- measurement range and resolution	-30 ÷ 80 °C (AR183), -50 ÷ 120 °C (AR182), resolution 0,1 °C
	- measurement accuracy	$\pm 0.5$ °C in the range of -10 to +80 °C ( $\pm 0.5 \div 1.7$ °C in the remaining range)
<b>Communication interfaces (standard equipment)</b>	<b>USB</b> (a A4 type connection, accessible also from the front)	- slave communication with a computer, drivers for the Windows XP/7/8/10 system: exchangeable disk + virtual COM serial port - master support of USB memory (pendrive) up to 4 GB
	<b>RS485</b> (galvanic separation)	MASTER (readout of 16-bit registers from Apar devices), SLAVE, baud rate 2.4 ÷ 115.2 kbit/s, character format 8N1
	<b>Ethernet</b> (RJ45, galvanic separation)	web server, MODBUS-TCP (server, client - readout of 16-bit registers from Apar devices), email client (SMTP), DDNS server client, DHCP (client, server), SMTP, NetBIOS, ICMP, data transfer up to 135 kB/s (depending on the network)
<b>Data recording interval</b>	programmable 1 s to 8 hours (1)	
<b>Data storage memory (non-volatile, recording of approx. 27 million measurements from 16 channels and 4 GB mem.):</b>		
	- internal	4 GB, micro SDHC card, industrial, MLC, FAT32 file system
	- external USB memory (pendrive, FLASH)	maximum size 4GB, FAT16, FAT32, standard A4 type socket
<b>Real time clock (RTC)</b>	date, time, takes leap years into account, lithium battery CR1220	
<b>Outputs (4 independent)</b>	- relays (P)	5A / 250Vac (for resistance loads), SPST-NO
	- SSR (optional)	transistor, type NPN OC, 24V, internal resistance 850 $\Omega$
<b>Display</b>	LCD TFT, 320x240 (QVGA), 3.5", background brightness adjustment	
<b>Power supply</b>	- 230Vac	85 ÷ 260 Vac/ 7VA
	- 24Vac/dc (optional)	20 ÷ 50 Vac/ 7VA, 22 ÷ 72 Vdc/ 7W
<b>Rated operating conditions</b>	0 ÷ 50 °C, <100 %RH (no condensation)	
<b>Operating environment</b>	air and neutral gases, no dust	
<b>Protection rating</b>	IP30 from the front, IP20 from the side of the connections	
<b>Electromagnetic compatibility (EMC)</b>	immunity: according to the PN-EN 61000-6-2, emission: PN-EN 61000-6-4	
<b>Safety requirements according to PN-EN 61010-1 standard</b>	overvoltage category: II	pollution degree: 2
	voltage to the ground (earth): 300 V for power supply and output relay circuits, 50 V for other inputs/outputs circuits and communication interfaces	
	insulation resistance > 20 M $\Omega$	height above sea level < 2000 m

(1) - for a recording interval equal to 1 s, uneven recording may take place during transfer of an archive via Ethernet and also because of an excessive number of files, their sizes, and type and manufacturer of the USB memory (pendrive) used  
(2) - for channels assigned to the Ethernet line, every missed response from the sensor causes an additional 3 sec. delay (the maximum waiting time for measurement from the Ethernet line for a single channel is equal to 3s)

## Wired temperature probe

(detailed technical data of the probe available at its datasheet)

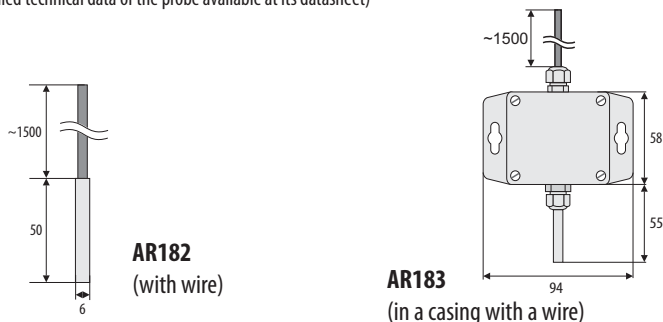

## ENCLOSURE AND INSTALLATION DATA

<b>Mounting</b>	panel, grips on the side of the enclosure
<b>Dimensions and weight</b>	96 × 96 × 79 mm, ~330 g
<b>Panel window</b>	92 × 89 mm
<b>Material</b>	self-extinguishing NORYL 94V-0, polycarbonate
<b>Conductor cross-sections (separable connectors)</b>	2,5mm <sup>2</sup> (supply and alarm outputs), 1,5mm <sup>2</sup> (others)

Dimensions in mm

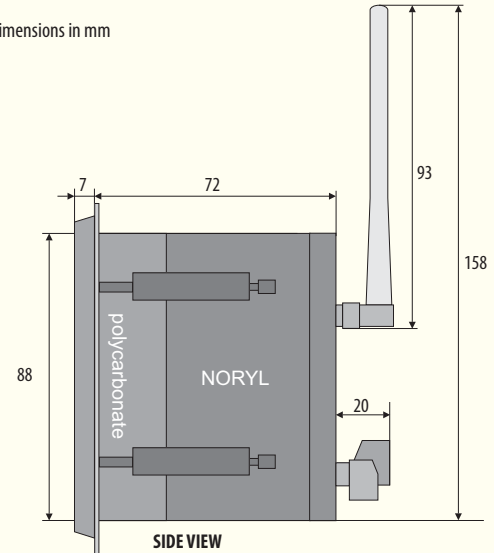

## TERMINAL BLOCK AND SOCKET

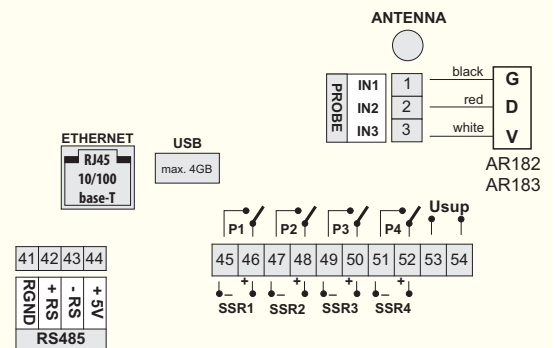

**NOTE:** A USB connection is also available on the front panel.  
**DO NOT USE SIMULTANEOUSLY!**

## How to order

AR407/ / / / / /

Supply	Code	Output 1, 2, 3, 4	Code
230 Vac	S1	relay	P
24 Vac/dc	S2	for SRR	S

**Order example:**  
AR407 / S1 / P / P / P / P  
supply 230 Vac, 4 relay outputs

Version 1.0.3 2018.06.12